



# Technical Report

No Polish Connector  
Single-mode SC Plug 8800

September 20, 2006

## **1.0 Background**

The 3M™ No Polish Connector (NPC) enables fast, on-site installation of 250µm and 900µm single-mode Fiber-to-the Premises (FTTP) connections using a one-piece pre-assembled design. The SC compatible connector incorporates a factory-polished ferrule and a mechanical splice that makes the connector easily terminated with a simple field tool. Systems integrators and installers for communication companies and private networks will find this connector to be one of the easiest way to make field terminations that improve the cable management inside buildings or in the outside plant.

## **2.0 Product Description & Requirements**

The 3M NPC single-mode SC/UPC utilizes a zirconia ceramic ferrule and high performance composite housing which allows full intermateability with any SC connector that meets industry de facto standards. This connector can be field terminated to 250µm acrylate coated and 900µm buffer coated fiber and used at 1310nm, 1490nm, 1550nm, and 1625nm wavelengths.

The components of the connectors are shown in the diagram below.

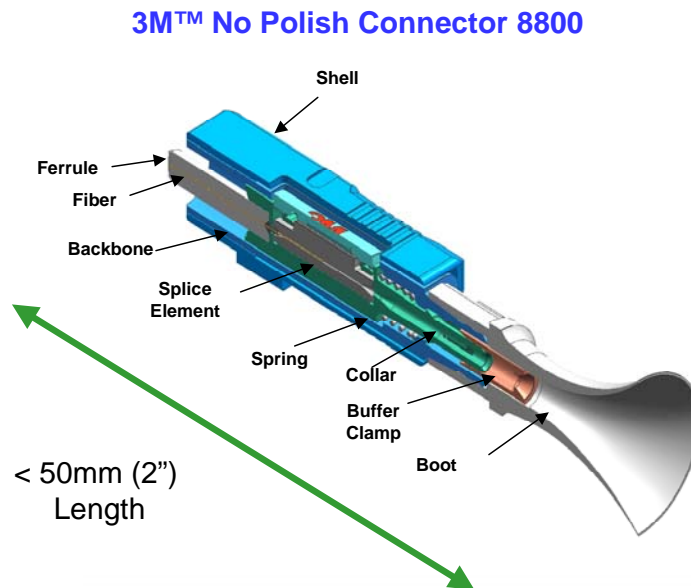

Figure 1. No Polish Connector Components

The 3M™ No Polish Connector Installation Tool allows the installer to easily align the prepared fiber with the entry funnel of the connector and activate the splice and buffer clamp using the same tool.

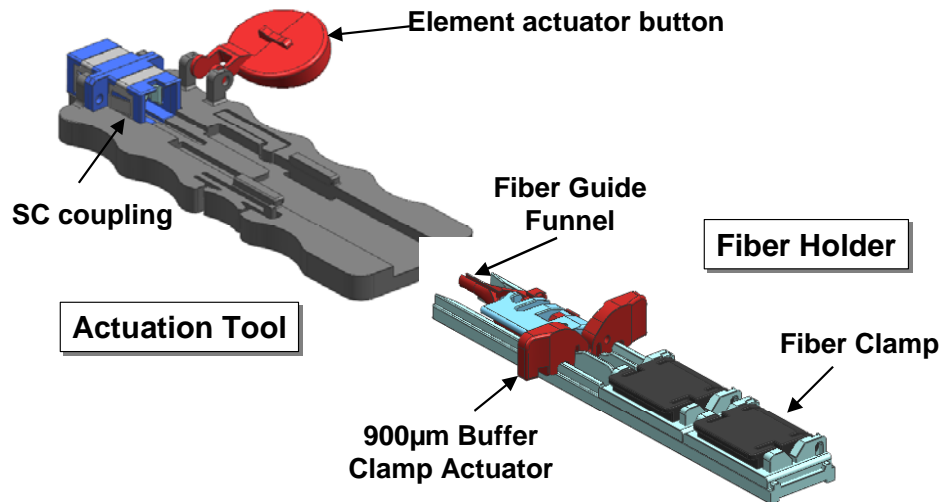

Figure 2. 3M™ No Polish Connector Installation Tool

### **3.0 Test Program**

The purpose of the test program is to assess the long-term performance of the 3M™ Singlemode SC No Polish Connector. A series of optical, environmental and mechanical tests were conducted which exposed the connectors to conditions more severe than those anticipated in typical use. Cable assemblies were created using standard work procedures and spliced into the test system. A list of tests performed is presented below.

<b>Test</b>	<b>Test Method</b>	<b>Conditions</b>
Insertion Loss	Initial connector insertion loss	Measure at room temperature
Return Loss	Initial connector return loss	Measure at room temperature
Vibration	Amplitude 1.52mm, 10-55-10Hz / period 4 mins/ period, 2 hours/ axis, 3 axis test	Measure insertion loss variation and max return loss during test
Strength	700 gram axial load at 100 mm from connector for 1 minute	Measure insertion loss variation after the test
Impact	4 meter height on each connector side for total of 4 times	Measure insertion loss variation after the test
Mating Durability	100 times	Measure insertion loss variation after the test
Temperature Cycling	-40°C to 75°C, 8 hours/ period, 96 hours	Measure insertion loss variation and max return loss during test
Humidity Aging	40°C, 95% Relative Humidity, 96 hours	Measure insertion loss variation and max return loss during test
Water Immersion	43°C, 3 days, measurement after 24 hours drying at 23°C	Measure insertion loss variation and max return loss during test

### 3.1 INITIAL TESTS

Sample Size: Thirty-three connectors were assembled as pigtails with 18 connectors on nylon 900µm buffer and 15 connectors on 900µm PVC buffer coated fibers and used for insertion loss testing.

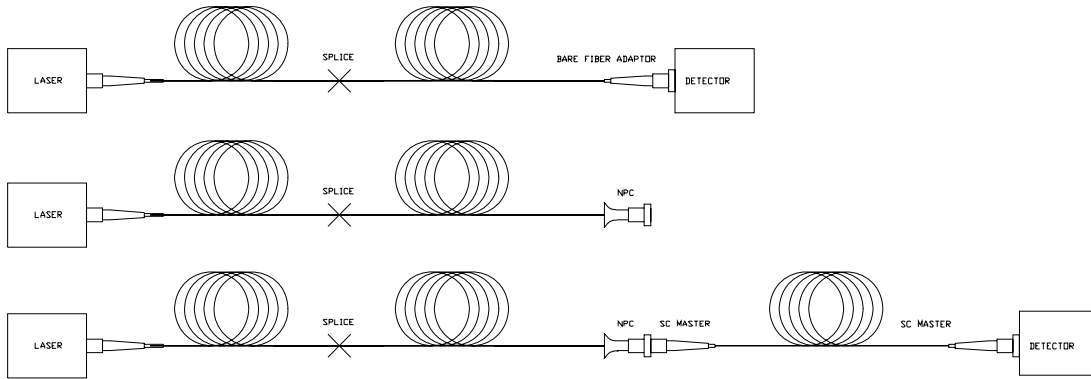
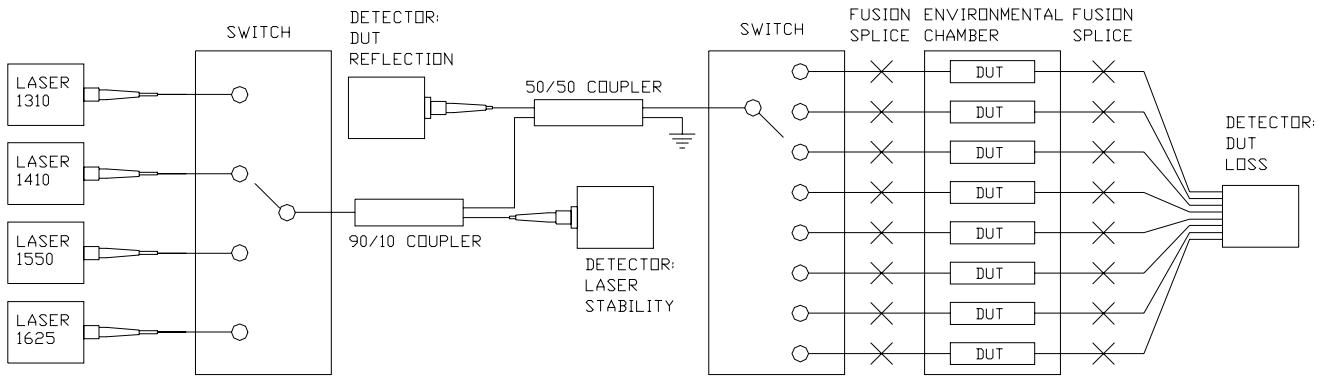

Figure 3. Insertion Loss Test Set-up

Sixty NPC connectors were terminated then connected to SC pigtails for reflection testing, humidity, immersion, thermal cycling and vibration tests.



“DUT” = Device under Test

Figure 4. Environmental Test System

Insertion loss of the 33 connectors and initial reflection loss of the 60 connectors are shown below.

Wavelength	Insertion Loss (dB)		Return Loss (dBm)	
	Mean	Maximum	Mean	Maximum
1310	-0.28	-0.55	-53.42	-47.37
1410	-0.27	-0.57	-54.37	-46.12
1550	-0.25	-0.47	-54.66	-46.14
1625	-0.26	-0.49	-54.07	-41.02

## **3.2 MECHANICAL TESTS**

### **3.2.1 VIBRATION**

**Procedure:**

Ten samples (5 nylon buffer and 5 PVC buffer) were subjected to a sinusoidal wave between 10 - 55 - 10Hz over a four-minute period at an amplitude of 1.52mm (0.06 inch). This is repeated for two hours, each in the X, Y, and Z planes for a total of six hours.

**Insertion Loss (dB)**

<u>Wavelength</u>	<u>Mean Loss Change</u>	<u>Max Loss Change</u>
1310nm	0.00	0.01
1490nm	0.01	0.15
1550nm	0.01	0.06
1625nm	0.01	0.15

**Return Loss (dB)**

<u>Wavelength</u>	<u>Final Mean</u>	<u>Final Max</u>
1310nm	-52.90	-48.01
1490nm	-54.71	-48.20
1550nm	-55.24	-49.15
1625nm	-53.96	-48.45

### **3.2.2 STRENGTH**

**Procedure:**

Ten samples (5 nylon buffer and 5 PVC buffer) were pulled axially by the fiber in a tensile testing machine. The samples were subjected to 700 grams (1.54lbs.) for one minute with the force applied at 10 centimeters (4 inches) from the ferrule interface.

**Insertion Loss (dB)**

<u>Wavelength</u>	<u>Mean Loss Change</u>	<u>Max Loss Change</u>
1550nm	0.01	0.06

### **3.2.3 IMPACT**

**Procedure:**

Ten samples (5 nylon buffer and 5 PVC buffer) were impact tested. The buffer fiber was secured in the clamp as shown in figure 5. Then the connector was raised to the horizontal position at a height of 4 meters (13 feet) and released in a manner such that it struck a concrete block. This was repeated 4 times, once for each connector face. The connector was cleaned prior to measuring the loss change. The connector was also inspected for any physical damage.

**Result:**

No physical damage seen.

**Insertion Loss (dB)**

Wavelength	Mean Loss Change	Max Loss Change
1550nm	0.00	0.19

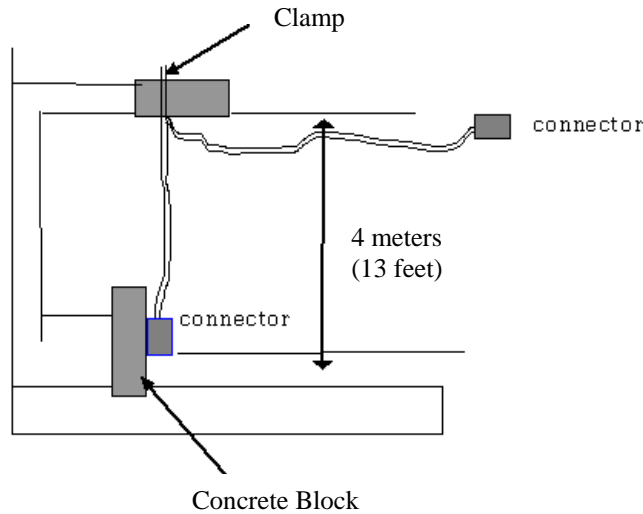

Figure 5. Impact Test Set-up

### **3.2.4 DURABILITY**

**Procedure**

Ten samples (5 nylon buffer and 5 PVC buffer) were assembled and mated to a SC connector 100 times. The connectors were cleaned after 100 cycles. The loss was measured immediately before and after the cleaning.

Insertion Loss (dB)	Before Cleaning		After Cleaning	
	Mean Loss Change	Max Loss Change	Mean Loss Change	Max Loss Change
Wavelength				
1550nm	0.00	0.07	0.02	0.15

### **3.3 ENVIRONMENTAL TESTS**

#### **3.3.1 THERMAL CYCLING**

**Procedure:**

Ten samples (5 nylon buffer and 5 PVC buffer) were subjected to thermal cycling. The measurement of loss and reflectance at 1310nm, 1490nm, 1550nm and 1625nm wavelengths were performed at the start and finish at 22°C (72°F), and every 0.25 hours during the test. The temperature range was -40° to +75°C (-40° to +167°F) for twelve 8-hour periods for a test duration of 96 hours. The temperature profile is illustrated in figure 6.

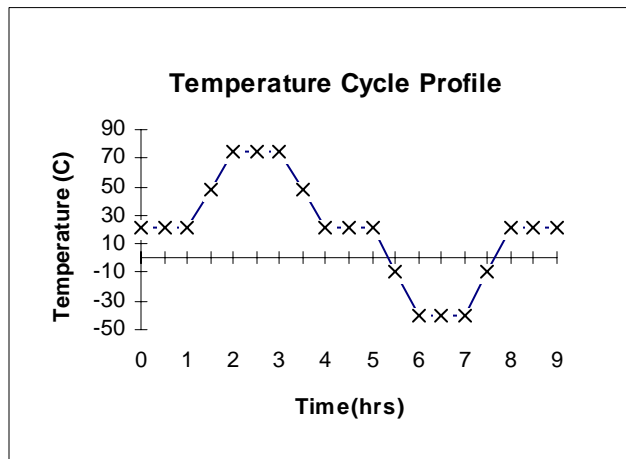

Figure 6. Temperature Profile

**Insertion Loss (dB)**

Wavelength	Mean Loss Change	Max Loss Change
1310nm	0.09	0.21
1490nm	0.07	0.13
1550nm	0.09	0.15
1625nm	0.12	0.19

**Return Loss (dB)**

Wavelength	Mean During Test	Max During Test
1310nm	-49.70	-35.44
1490nm	-49.04	-36.41
1550nm	-48.60	-33.75
1625nm	-47.90	-34.67



### **3.3.2 HUMIDITY AGE**

**Procedure:**

Ten samples (5 nylon buffer and 5 PVC buffer) were subjected to humidity aging. The measurement of loss and reflectance at 1310nm, 1490nm, 1550nm and 1625nm wavelengths was performed at the start and finish at 22°C (72°F), and every 20 minutes during the test at 40°C, (104°F) 95% relative humidity. The test duration was 96 hours (4 days).

**Insertion Loss (dB)**

<u>Wavelength</u>	<u>Mean Loss Change</u>	<u>Max Loss Change</u>
1310nm	0.04	0.07
1490nm	0.05	0.07
1550nm	0.06	0.15
1625nm	0.09	0.25

**Return Loss (dB)**

<u>Wavelength</u>	<u>Mean During Test</u>	<u>Max During Test</u>
1310nm	-47.67	-40.97
1490nm	-51.77	-42.41
1550nm	-51.99	-47.04
1625nm	-51.48	-46.82

### **3.3.3 WATER IMMERSION**

**Procedure:**

Ten samples (5 nylon buffer and 5 PVC buffer) were immersed in water at 43°C (109°F) for 72 hours (3 days). The measurement of loss and reflectance at 1310nm, 1490nm, 1550nm and 1625nm wavelengths were performed during the immersion and during the subsequent 24 hour dry time at 23°C (73°F) outside the chamber.

**Insertion Loss (dB)**

<u>Wavelength</u>	<u>Mean Loss Change</u>	<u>Max Loss Change</u>
1310nm	0.07	0.10
1490nm	0.05	0.10
1550nm	0.07	0.15
1625nm	0.08	0.15

**Return Loss (dB)**

<u>Wavelength</u>	<u>Mean During Test</u>	<u>Max During Test</u>
1310nm	-50.88	-42.13
1490nm	-51.20	-42.89
1550nm	-51.33	-42.35
1625nm	-51.90	-40.70

## **4.0 CONCLUSION**

Throughout this test program the 3M™ No Polish Connector demonstrated low insertion loss, low reflectance, environmental stability and physical robustness. This connector will ensure a reliable, optical communication link.

For information, please contact your 3M Telecom representative.

3M and Fiblok are trademarks of 3M Company.

### **Important Notice**

All statements, technical information, and recommendations related to 3M's products are based on information believed to be reliable, but the accuracy or completeness is not guaranteed. Before using this product, you must evaluate it and determine if it is suitable for your intended application. You assume all risks and liability associated with such use. Any statements related to the product which are not contained in 3M's current publications, or any contrary statements contained on your purchase order shall have no force or effect unless expressly agreed upon, in writing, by an authorized officer of 3M.

#### **Warranty; Limited Remedy; Limited Liability.**

This product will be free from defects in material and manufacture for a period of 12 months from the time of purchase. **3M MAKES NO OTHER WARRANTIES INCLUDING, BUT NOT LIMITED TO, ANY IMPLIED WARRANTY OF MERCHANTABILITY OR FITNESS FOR A PARTICULAR PURPOSE.** If this product is defective within the warranty period stated above, your exclusive remedy shall be, at 3M's option, to replace or repair the 3M product or refund the purchase price of the 3M product. **Except where prohibited by law, 3M will not be liable for any loss or damage arising from this 3M product, whether indirect, special, incidental or consequential regardless of the legal theory asserted.**



**Communication Markets Division  
3M Telecommunications**

6801 River Place Blvd.  
Austin, TX 78726-9000  
800/426 8688  
Fax 800/626 0329  
www.3MTelecommunications.com

*Please Recycle*

© 3M 2006 80-6113-1565-8